

		3A/45V. Die Size-60mil.		
				
Electrical Characteristics	Symbol	Unit	Spec. limit	Die Sort
Breakdown Voltage @ $I_R=10\text{mA}$	$V_{BR}$	V	45	50
Average Rectified Forward Current	$I_{F(AV)}$	A	3,0	-
DC Forward Voltage @ $25^\circ\text{C}$ , $I_F=3,0\text{A}$	$V_F$	V	0,68	0,66
Maximum Reverse Current @ $25^\circ\text{C}$ , $V_R=45\text{V}$ @ $125^\circ\text{C}$ , $V_R=45\text{V}$	$I_R$	mA	0,010 10,0	0,008 8,0
Peak Forward Surge Current 8,3ms single half sine-wave superimposed on rated load (JEDEC METHOD)	$I_{FSM}$	A	90	-
Peak Repetitive Reverse Surge Current @ $2,0\mu\text{s}$ , $f=1\text{kHz}$ ., $T_J<175^\circ\text{C}$ .	$I_{RRM}$	A	2,5	
Electrostatic Discharge Voltage. JEDEC Method. ESD HBM. Contact.	$V_{ESD}$	kV	$\pm 8$ (contact)	
Voltage Rate of Change	$dV/dt$	$\text{V}/\mu\text{s}$	10.000	
Operating Junction Temperature	$T_J$	$^\circ\text{C}$	175	

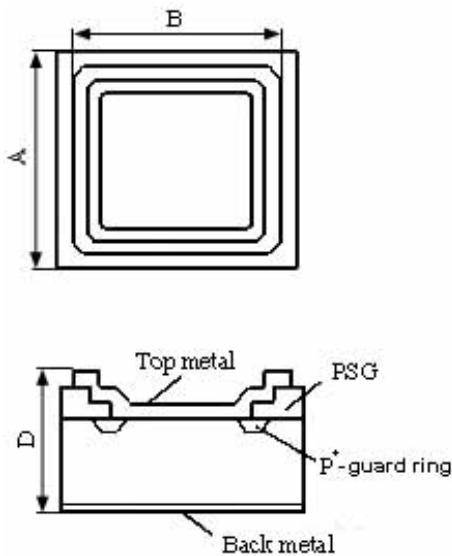

DIM	ITEM	$\mu\text{m}$
$A_x$	Wafer Form Die Size	1520
$A_y$		1520
$B_x$	Top Metal Size	1380
$B_y$		1380
D	Thickness	300max.
Scribe line Width		80

Top metal:

a) **Al-Ni-Ag** – for Soldering;

b) **Al** – for Wire Bonding.

Backside metal: **Ti-Ni-Ag**.